



# Tulsa Valve

*We Control The Flow*



## Casing Ball Valves

ISO 9001:2000 Certified  
Certificate No. C2007-01814





## Carbon Steel - Ductile Iron - Stainless Steel

Casing Valve manufactured in compliance with:

API 5B

ASME B3.1 Pipe Threads

NACE MR0175-2003

Limited Compliance to:

ASME B16.34 Wall Thickness

ASME B&PVC Sections 2 and 8 Design and Material Requirements

API 6D and API 6A Design Requirements

API 608

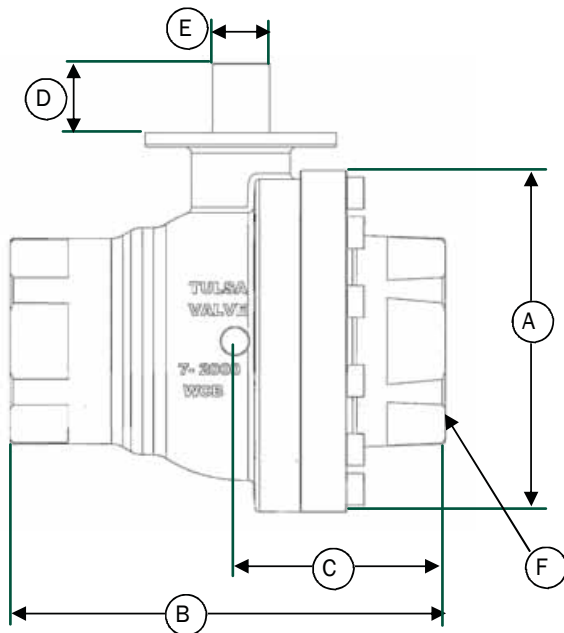

## Series E

**Casing Ball Valves** by Tulsa Valve were originally developed for the casing plunger industry, however our Casing Ball Valve now enjoys service in many other applications throughout the valve industry. Tulsa Valve Casing Ball Valves provide the oil patch with a dependable, trouble free, quality Casing Ball Valve.

Our Casing Ball Valve incorporates many features which include a backseated stem that is blowout proof. The stem area is grease-packed and protected by our external stop plate which serves two purposes: to guard the stem from external elements, and to give dual precise stopping support during opening and closing. Made with Long Casing Threads for easy use. All of our Casing Ball Valves conform to NACE MR0175 requirements. Tulsa Valve performs 100% pressure testing on all of our Casing Ball Valves.

### Features Include:

- Long form Casing Threads.
- Ductile Iron, Carbon Steel or Stainless Steel.
- Ductile Iron: 2000 WOG Pressure Range
- Carbon Steel : 3000 WOG Pressure Range
- Stainless Steel : 3000 WOG Pressure Range
- 4", 5" and 7" casing thread sizes.
- Field Repairable

Size	Material	Cat. No.	Port	W.P.	A	B	C	D	E	F
	Ductile Iron	4F-E44DI8R	4	2000	9 11/16	13 1/4	6 1/16	1 3/8	1.37	8 Round
4 x 4 x 4	Ductile Iron	4F-E44DI8V	4	2000	9 11/16	13 1/4	6 1/16	1 3/8	1.37	8 V
	Carbon Steel	4F-E44CS8R	4	3000	9 11/16	13 1/4	6 1/16	13/8	1.37	8 Round
5 x 5 x 5	Ductile Iron	5F-E55DI8R	5	2000	11 1/4	16 3/8	6 7/8	1 3/8	1 3/8	8 Round
	Stainless Steel	5F-E55SS8R	5	3000	11 1/4	16 3/8	6 7/8	1 3/8	1 3/8	8 Round
6 x 6 x 6	Carbon Steel	7F-E77CS8R	7	3000	14 3/4	18 3/4	8 13/16	3	2.5	8 Round

	Part Name
1	Body
2	Ball
3	Stem
4	Seat
5	Stem O'Ring
6	Thrust Bearing
7	Stop Plate (not shown)
8	Snap Ring (not shown)
9	Body Bolts
10	Adapter
11	Adapter O'Ring

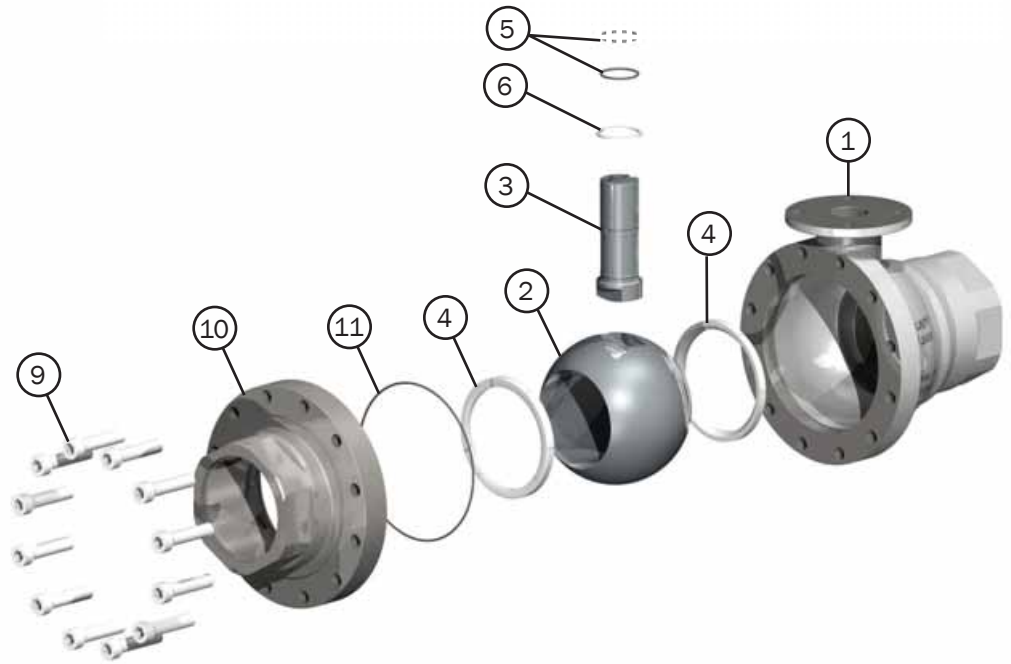

## Material Specifications

	Part	Ductile Iron	Carbon Steel	Stainless Steel
1	Body	ASTM A395 Ductile Iron	ASTM 352 LCC Carbon Steel	ASTM A351 Stainless Steel
2	Ball	ASTM A351 Stainless Steel	ASTM A351 Stainless Steel	ASTM A351 Stainless Steel
3	Stem	4140 Zinc Plated	316 SS Annealed	316 SS Annealed
4	Seat	Nylon (RTFE Optional)	Nylon (RTFE Optional)	Nylon (RTFE Optional)
5	Stem O'Ring	Buna-N 70 Duro (Viton Optional)	Buna-N 70 Duro (Viton Optional)	Buna-N 70 Duro
6	Thrust Bearing	PTFE	PTFE	PTFE
7	Stop Plate	A36 CS Plated	A36 CS Plated	A36 CS Plated
8	Snap Ring	Spring Steel	Spring Steel	Spring Steel
9	Body Bolts	ASTM A574 (SAE Grade 5 on 7")	ASTM A193 B7M	ASTM A193 B8M
10	Adapter	ASTM A395 Ductile Iron	ASTM 352 LCC Carbon Steel	ASTM A351 Stainless Steel
11	Adapter O'Ring	Viton 75 Duro	Viton 75 Duro	Viton 75 Duro

# Casing Ball Valves



Tulsa Valve is an oil field and industrial valve manufacturer. Tulsa Valve Products are made of the highest quality materials and workmanship. We test every valve to the appropriate standards and maintain material and product traceability on all valves. Our valves are designed to meet the customers best expectations and we pride ourselves on our ability to meet these expectations.

**Products we manufacture:** Ball Check Valves, Threaded Swing Check Valves, Shut-off Pig Valves, By-pass Pig Valves, Casing Ball Valves, and Flanged Check Valves.

*Tulsa Valve is a member of Array Holdings, a group of affiliated companies proudly serving the domestic and international energy industry.*

## Terms and Conditions

**Warranty:** Tulsa Valve products are guaranteed against defects of material workmanship for One (1) Year from date of invoice provided such products are used normally and within the service and pressure range for which they were manufactured. This guarantee is limited to the repair, replacement or repayment of purchase price. Under no conditions will Tulsa Valve be liable for claim of labor for removal, repair or replacement of Tulsa Valve products, or any other consequential damage.

**Cancellation:** Firm orders which have been accepted and entered are not cancellable except by written authorization from Tulsa Valve, unused material may be returned upon written consent from Tulsa Valve and credit will be issued only on material returned within one year from date of purchase. Tulsa Valve reserves the right to deduct reconditioning and handling charges when issuing credit for returned material. Credit may be used only for the purchase of merchandise and is not subject to cash reimbursement or cash payments.



P.O. Box 35  
Cleveland, OK 74020  
1-800-895-1380  
Phone: (918)358-3494 • Fax: (918)358-3595  
Email: sales@tulsavalve.com